



SVT Series Vertical Transporter

SVT-700



Refer carefully to this manual before operation.

SVT Series

■ Coding Principle

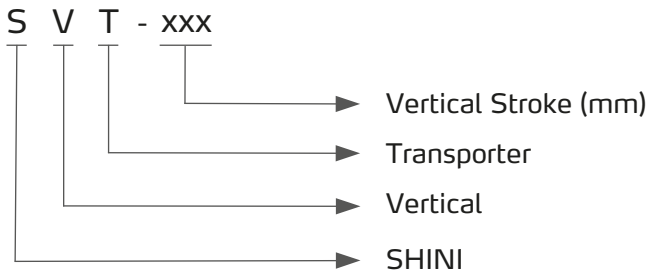

■ Features

- Connect with robot signal, catch products accurately and protect the products.
- Auto up, down and tilt, transport products to workbench.
- The trays of vertical transporter nice looking and wearable avoid scratching products.
- Two-point composition and quick-connectors for conveniently usage.
- The up and down stroke can be adjusted.

■ Application

The SVT Series vertical transporter is designed for catching products after robot picks them out from injection molding machine. The signals connect with robot, catch products accurately and safety, with two-point composition and quick-connectors, the up and down stroke can be adjusted, conveniently and rapidly, improve the production efficiency and protect operator's safety.



SVT-700 (Lateral)

Outline Drawings

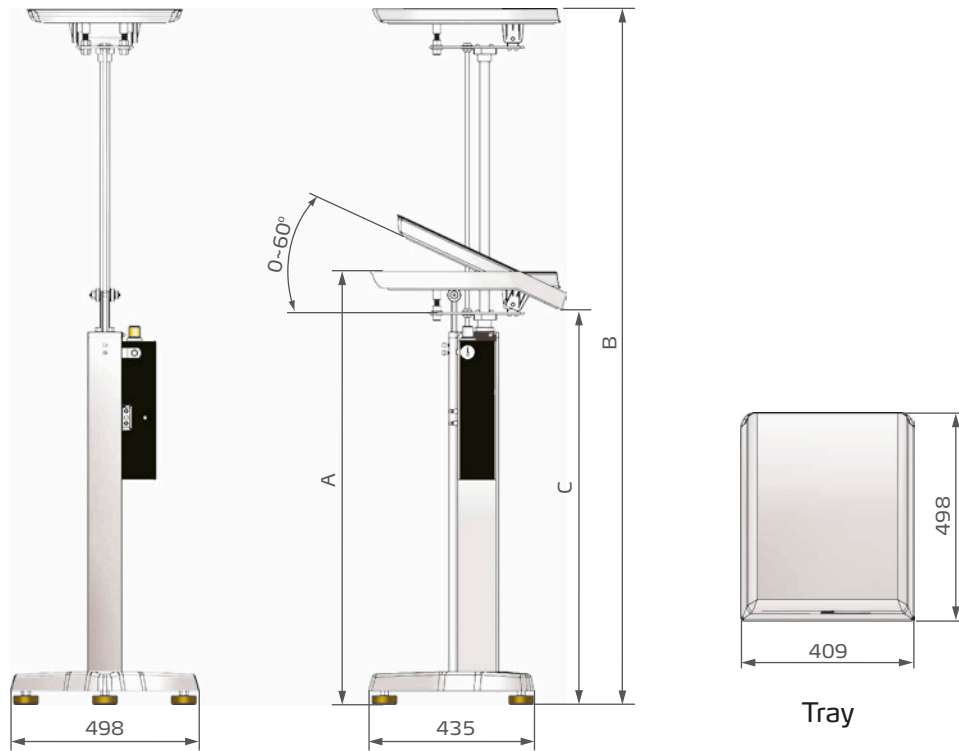

Specifications

Model	SVT-500	SVT-600	SVT-700	SVT-800
A (mm)	930	1030	1130	1230
B (mm)	1450	1650	1850	2050
C (mm)	804	904	1040	1140
Net Weight (kg)	36	38	40	42
Dimensions (mm) D×W×H	498 × 498 × 930	498 × 498 × 1030	498 × 498 × 1130	498 × 498 × 1230
Power Source (V)	DC 24V			
Air Pressure (bar)	5			
IMM (ton)	50 ~ 250			
Max Load (with tool) (kg)	2			
Air Consumption(Nl/cycle)	0.5			

We reserve the right to change specifications without prior notice.